



L&R INTERNAL USE ONLY

TributeNight™ Leg Order Form

1 Patient Information

Name: _____ Phone Number: _____ Age: _____ Height: _____ Weight: _____

Therapist/Fitter: Name: _____ Phone Number: _____ Email: _____

2 Garment Design

Style Right Leg Left Leg LE - _____

Channeling Chevron Vertical

Profile Original Low

Color Black Slate Purple Raspberry

Modifications

QTY.	Notes/Placement Instruction
<input type="checkbox"/> Zippers	_____
<input type="checkbox"/> VELCRO® fastener Closure	_____
<input type="checkbox"/> Adjustable panels	_____
<input type="checkbox"/> Non-skid pads	_____
<input type="checkbox"/> Pull-up loops	_____
<input type="checkbox"/> Snap tape	_____

Accessories

- Variable Compression Jacket (VCJ)
- Outer Jacket (OJ)
 - Color: Black Slate Purple Raspberry
 - Fastener type: VELCRO® Snap
 - Modifications: Non-skid pads
- Easy Slide Donning Aid

Special Instructions: _____

Exact Reorder of Order #: _____

4 Billing Information

Quote Only

Business Name: _____

Phone: _____ Fax: _____

Contact Name & Phone: _____

Account #: _____ P.O. #: _____

Payment: Credit card (provide number below) Net 30

Card #: _____ Exp: ____ / ____ SID: _____

3 Measurements

Date taken: ____ / ____ / ____

(All measurements in centimeters)

C = Circumference

L = Length

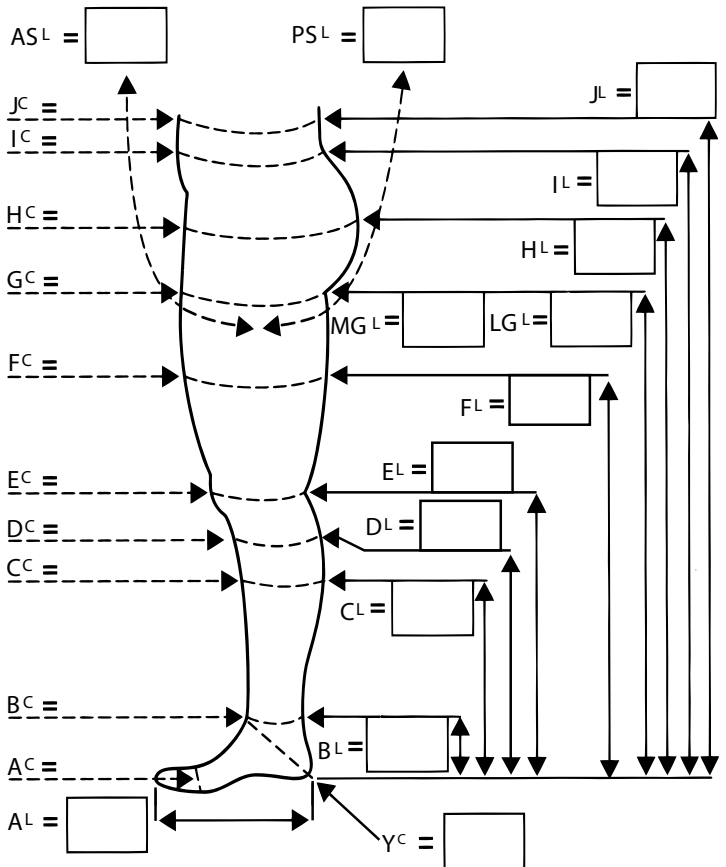

5 Shipping Information

Shipping: Standard 4-Day Guarantee*
Priority Requested Delivery Date: _____

Ship to: _____

Attn: _____

Street: _____

City: _____ State: _____

Phone: _____ Zip: _____

Email (for shipping notification): _____